



**Model number**

**IMU360D-F99-B20-V15**

Inertial measurement unit 6-axis

**Features**

- **Measurement of inclination, acceleration and rotation rate in 3 axes each**
- **Compensation of dynamic disturbance**
- **F99-Fusion technology**
- **CAN bus with SAE J1939 protocol**
- **High EMC resistance**

**Function description**

The IMU360D-F99, with the F99-Fusion technology, is optimized to provide gyroscopic stabilized inclination and acceleration data as well as rotation rate data. Several selectable output values such as acceleration, rotational speed, inclination (Euler angle, Euler value, quaternions) and programmable filters allow you to perfectly adapt the measuring system to your application.

**Electrical connection**

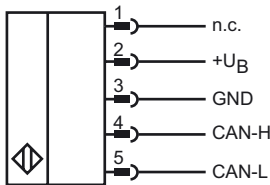

Release date: 2018-05-03 15:57 Date of edition: 2018-05-03 287211\_eng.xml

**Technical Data**

**General specifications**

Type	Inertial measurement unit
Measurement range	acceleration: $\pm 2 \text{ g}$ inclination: $0 \dots 360^\circ$ rotation rate: $\pm 250 \text{ }^\circ/\text{s}$
<b>Static accuracy</b>	
Measurement range $\leq 150^\circ$	$\leq \pm 0.5^\circ$
Measurement range $> 150^\circ$	$\pm 1^\circ$
<b>Dynamic accuracy</b>	
Measurement range $\leq 150^\circ$	linear acceleration: $\leq \pm 0.5^\circ$ up to $0.5 \text{ m/s}^2$ for an acceleration time $\leq 2\text{s}$
Measurement range $> 150^\circ$	linear acceleration: $\leq \pm 1^\circ$ up to $0.5 \text{ m/s}^2$ for an acceleration time $\leq 2\text{s}$
Resolution	$0.01^\circ$
Repeat accuracy	$\leq \pm 0.1^\circ$
Cycle time	internal 10 ms
Temperature influence	max. $\pm 1.5^\circ$ ( $-40 \dots 85^\circ\text{C}$ ( $-40 \dots 185^\circ\text{F}$ ))

**Functional safety related parameters**

MTTF <sub>d</sub>	530 a
Mission Time (T <sub>M</sub> )	10 a
Diagnostic Coverage (DC)	0 %

**Indicators/operating means**

Operation indicator	LED, green
Status indicator	LED, yellow
Error indicator	LED, red

**Electrical specifications**

Operating voltage U <sub>B</sub>	5 ... 30 V DC
No-load supply current I <sub>0</sub>	$\leq 80 \text{ mA}$
Power consumption P <sub>0</sub>	$\leq 0.6 \text{ W}$

**Interface**

Interface type	CAN bus with SAE J1939 protocol
Transfer rate	10 ... 1000 kBit/s, programmable
Node ID	0 ... 253, programmable
Termination	external
Cycle time	output interval programmable

**Ambient conditions**

Ambient temperature	$-40 \dots 85^\circ\text{C}$ ( $-40 \dots 185^\circ\text{F}$ )
Storage temperature	$-40 \dots 85^\circ\text{C}$ ( $-40 \dots 185^\circ\text{F}$ )

**Mechanical specifications**

Connection type	5-pin, M12 x 1 connector 5-pin, M12 x 1 socket internal bridged
-----------------	---

Housing material	PA
Degree of protection	IP68 / IP69K
Mass	240 g

**Factory settings**

Node ID	128
Transfer rate	250 kBit/s

**Compliance with standards and directives**

Standard conformity	
Shock and impact resistance	100 g according to DIN EN 60068-2-27
Standards	EN 60947-5-2:2007 EN 60947-5-2/A1:2012 IEC 60947-5-2:2007 IEC 60947-5-2 AMD 1:2012

**Approvals and certificates**

UL approval	cULus Listed, Class 2 Power Source
E1 Type approval	10R-04

**Dimensions**

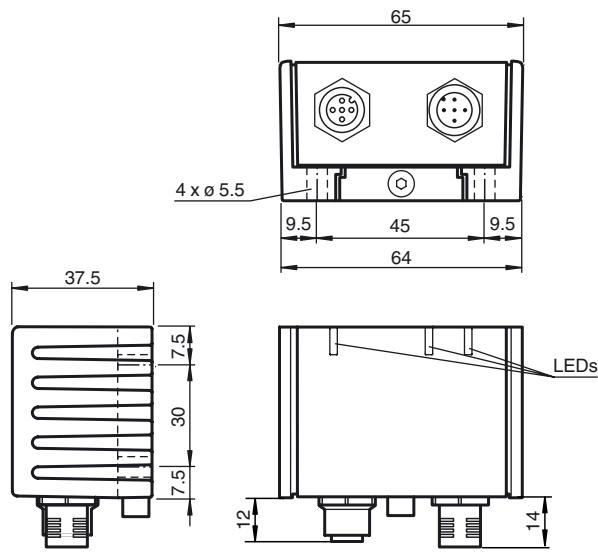

**Pinout**

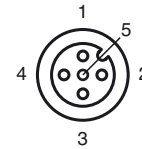
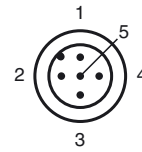

Wire colors in accordance with EN 60947-5-2

1	BN	(brown)
2	WH	(white)
3	BU	(blue)
4	BK	(black)
5	GY	(gray)

**EMC Properties**

Interference immunity in accordance with  
DIN ISO 11452-2: 100 V/m

Frequency band 20 MHz up to 2 GHz

Mains-borne interference in accordance with ISO 7637-2:

Pulse	1	2a	2b	3a	3b	4	5
Severity level	III	III	III	III	III	III	IV
Failure criterion	C	A	C	A	A	A	A

EN 61000-4-2: CD: 8 kV / AD: 15 kV

Severity level IV IV

EN 61000-4-3: 30 V/m (80...2500 MHz)

Severity level IV

EN 61000-4-4: 2 kV

Severity level III

EN 61000-4-6: 10 V (0.01...80 MHz)

Severity level III

EN 55011: Klasse A

**Accessories**

**V15-G-2M-PUR-CAN-V15-G**

DeviceNet/CANOpen bus cable, M12 to M12, PUR cable 5-pin

**V15-G-5M-PUR-CAN-V15-G**

DeviceNet/CANOpen bus cable, M12 to M12, PUR cable 5-pin

**V15-G-10M-PUR-CAN-V15-G**

DeviceNet/CANOpen bus cable, M12 to M12, PUR cable 5-pin

**ICZ-TR-CAN/DN-V15**

Terminal resistor for DeviceNet, CANOpen

**Orientation**

Assignment of the axis to movement types with P + F angle

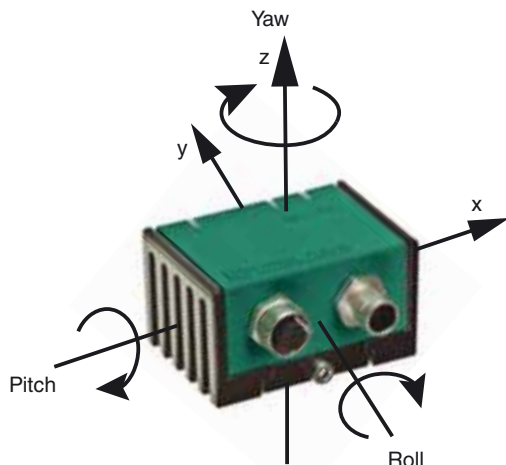

Assignment of the axis to movement types with Euler angle

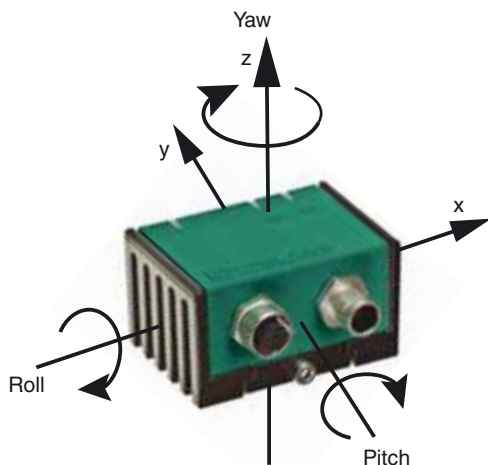

**Mounting of the sensor**

Sensors from the -F99 series consist of a sensor module and accompanying cast aluminum housing. Select a flat surface with minimum dimensions of 70 mm x 50 mm to mount the sensor.

Mount the sensor as follows:

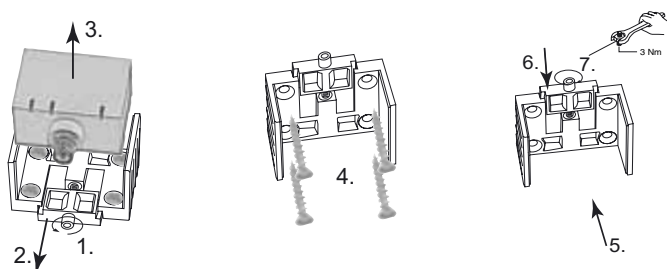

1. Loosen the central screw under the sensor connection.
  2. Slide back the clamping element until you are able to remove the sensor module from the housing.
  3. Remove the sensor module from the housing
  4. Position the housing at the required mounting location and secure using four countersunk screws. Make sure that the heads of the screws do not protrude.
  5. Place the sensor module in the housing.
  6. Slide the clamping element flush into the housing. Check that the sensor element is seated correctly.
  7. Finally tighten the central screw.
- The sensor is now mounted correctly.

Release date: 2018-05-03 15:57 Date of edition: 2018-05-03 287211\_eng.xml